

# Assessment of the thermal environment effects on human comfort and health for the development of novel air conditioning system in tropical regions

Thammanoon Sookchaiya, Veerapol Monyakul, Sirichai Thepa\*

Division of Energy Technology, School of Energy Environment and Materials, King Mongkut's University of Technology Thonburi, Bangkok, Thailand

## ARTICLE INFO

### Article history:

Received 2 December 2009

Received in revised form 21 March 2010

Accepted 30 April 2010

### Keywords:

Precision air conditioner  
Inverter  
Dehumidification  
Healthy  
Delphi Technique  
Thermal Comfort

## ABSTRACT

This research shows the result of a brainstorming by medical experts in the first ranking university medical school and hospital of Thailand. It was based on Delphi technique. The objective of this research was to study both direct and indirect effects of humidity and temperature on human health in air-conditioned buildings in Thailand. Afterwards, the result was used to design and develop split type air conditioner (conventional air conditioner) which could control relative humidity and temperature with precision air conditioning system to comply with the climate and the suitability of the people living in Thailand building. The result of operation with precision inverter air conditioning system showed that the temperature inside the room changed from the default value around  $\pm 0.2^\circ\text{C}$  (Case 1) and around  $\pm 0.35^\circ\text{C}$  (Case 2) and it could control relative humidity as a desired condition between 50–60% (both cases) which was the appropriate range for Thai climate. Moreover, energy consumption of precision inverter air conditioning system was still less than conventional air conditioning system for about 7.5%. This research could provide people living in Thailand air conditioned building with human thermal comfort and health.

© 2010 Elsevier B.V. All rights reserved.

## 1. Introduction

Thermal indoor environment in the building is very important because most people spent around 90% of their time in building. Therefore, optimal thermal indoor environment is necessary for everybody [1,2]. Major physical factors which affect thermal indoor environment are air temperature, relative humidity, air movements and radian temperature [1,3,4]. The target climate for human occupation may explicitly or implicitly be aimed at achieving human thermal comfort and health or improved productivity [3].

Thermal comfort is a reaction which humans can feel concerning heat and cold [3]. The thermal comfort depends on the occupants' clothing and their level of activity and is a function of the air temperature and their local distributions, surface temperatures and its distribution, air humidity and air movement [4]. A room with thermal comfort means a room where 80% of all persons inside could accept the environment [5]. The design of buildings and offices must depend on human comfort, especially in hospital buildings where there are patients, staff members and other relevant persons under the risk of infection through germs, bacteria, virus and the like [6–8]. The control of appropriate thermal environment, therefore, is important for thermal comfort and good health for the persons in hospital [9].

Thermal comfort is an important factor for designing high-quality buildings in order to create comfortable environment and good health for people living in the buildings [10]. Air conditioning and ventilation systems are installed inside the buildings to build a comfort indoor environment [2]. Most people understand that good air conditioning is just the control of temperature or ventilation which builds up comfort or good health but there are so many people in such environment who suffer for nose irritations, stuffed nose, rainy nose, eye irritations, cough, tightness in the chest, fatigue, headache, rash and a lot more. These symptoms are normally called “Sick Building Syndrome” or SBS which is affected by relative humidity [11]. Relative humidity affects the rate of evaporation in the air and affects the energy balance in the body and it is relative to human thermal comfort [12].

### 1.1. Relative humidity effects on human thermal comfort and health

Case studies and research on epidemiology suggest that relative humidity has a direct effect on cell membrane which is related to respiration, contraction, nose tissue inflammations or influenza and fever. It also has an indirect effect on the growth of allergies and respiratory diseases along with the existence of diseases like fungi (e.g., *Aspergillus fumigatus*), protozoa, house dust mite, bacteria (e.g., *Streptococcus*, *Legionella*) and virus (e.g., common cold, flu) [7]. Relative humidity also affects the intensity of chemical pollution in the air by changing the distribution rate of gas from the

\* Corresponding author. Fax: +66 24708623.

E-mail addresses: [noon.kmutt@gmail.com](mailto:noon.kmutt@gmail.com), [drsirichai@yahoo.com](mailto:drsirichai@yahoo.com) (S. Thepa).

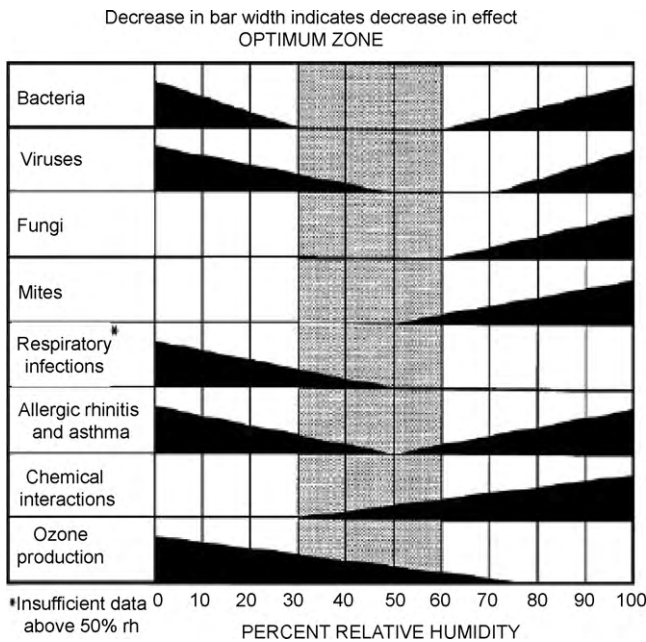

Fig. 1. Optimum relative humidity range for minimizing adverse health effects.

materials used inside the buildings and the reaction between water and chemicals in the air. The majority of adverse health effects caused by relative humidity would be minimized by maintaining indoor levels between 40 and 60% as shown in Fig. 1 [11].

Air temperature and humidity must be maintained at acceptable levels because it is closely related to the space hygiene and thermal comfort conditions [13]. Air temperature and relative humidity have an effect on IAQ, thermal comfort and health [14]. Therefore, there were studies on thermal comfort, IAQ in buildings and residence [15,16]. There were also studies on thermal comfort and the effects of relative humidity on patients in hospital building such as Lester [17] who studied the influence of relative humidity on the infectivity of air-borne influenza A virus (PR8 Strain). Skoog et al. [1] studied Thermal environment in Swedish hospital: summer and winter. Hashiguchi et al. [18] studied Effect of setting up of humidifiers on thermal conditions and subjective responses of patients and staff in a hospital during winter. Atmaca and Yigit [19] studied predicting the effect of relative humidity on skin temperature and skin wettedness. Hwang et al. [9] studied patient thermal comfort requirement for hospital environments in Taiwan. Moreover, there were also studies on Effect of humidity on human comfort and productivity [20,21]. According to the results in all studies, it was found that relative humidity in the optimal range offers thermal comfort and good health.

Lowen et al. [22] studied Transmission of Influenza virus from guinea pig to guinea pig and found that influenza virus transmission is dependent on relative humidity and temperature. The result was shown in Fig. 2.

Hemmers et al. [23] reported that environment with relative humidity lower than 50% will increase the spreading rate of influenza virus. Low humidity is also related to come a tissue weakness. Hiraga et al. [24] installed an ultrasonic device to increase the humidity in 222 houses. The results were that an appropriate increase in humidity is useful to reduce various diseases and respiratory diseases. Tsutsumi et al. [25] tested the effect of low humidity on comfort and other results in participants under stable circumstance in summer. Ibamoto et al. [26] reported that low humidity was possible for thermal comfort in both transient and steady state.

The relative humidity of indoor environments has both direct and indirect effects on health and comfort. The direct effects are the

result of the effect of relative humidity on physiological processes, whereas the indirect effects result from the impact of humidity on pathogenic organisms or chemicals [11].

1.2. Air Conditioning System and Comfort

“Electric Power in Thailand 2009” report is published annually by the Department of Alternative Energy Development and Efficiency (DEDE), Ministry of Energy. It was reported that Thailand electricity consumption of national grid in 2009 was 135,420 Gwh. The industrial, commercial, residential, agricultural, transportation and others sector consumed electricity 57,850 Gwh, 45,899 Gwh, 30,597 Gwh, 317 Gwh, 59 Gwh and 698 Gwh, respectively, and accounted for 42.72%, 33.89%, 22.59%, 0.23%, 0.04% and 0.52% of the total electric consumption for the whole country respectively. It could be seen that commercial (including government sector and non-profit organizations) and residential sector consumed electricity 76,496 Gwh and accounted for 56.49% of the total electric consumption for the whole country.

Electricity consumption in residential and commercial sector (such as hotels, hospitals, schools, department stores and offices) amounts to approximately 50.75% (38,822 Gwh), namely electricity consumption of air conditioning system. The building in this sector consumed electricity consumption of split-type air conditioning system not less than 70% (27,175 Gwh) of the total electricity consumption of air conditioning system and accounted for 20% of the total electric consumption for the whole country.

Heating, ventilating and air conditioning (HVAC) installations control indoor air quality and aseptic conditions, and secure healthy, safe and suitable indoor thermal(i.e. temperature, humidity, air quality and airflow) conditions for surgeons and medical staff, and of course, the patients [13].

The design and installation of air conditioning system to control thermal environment to achieve human thermal comfort and health inside buildings should comply with the ASHRAE Standard 55-2004 which is the most appropriate [27]. Comfortable thermal environment in hospital can make the patients and staff members feel good and better [9]. The control of relative humidity as in ASHRAE 2001 (item 8.12) reads that relative humidity to achieve thermal comfort should not exceed 60% [28]. Thus, air-conditioning system was installed in the building to control thermal environment so that it is in Comfort zone according to the ASHRAE Standard 55-2004 [27] (Fig. 3).

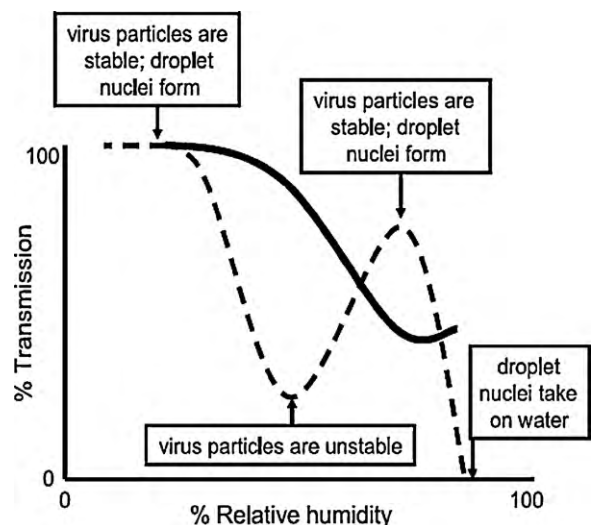

Fig. 2. Variation of Transmission Efficiency with Relative Humidity.

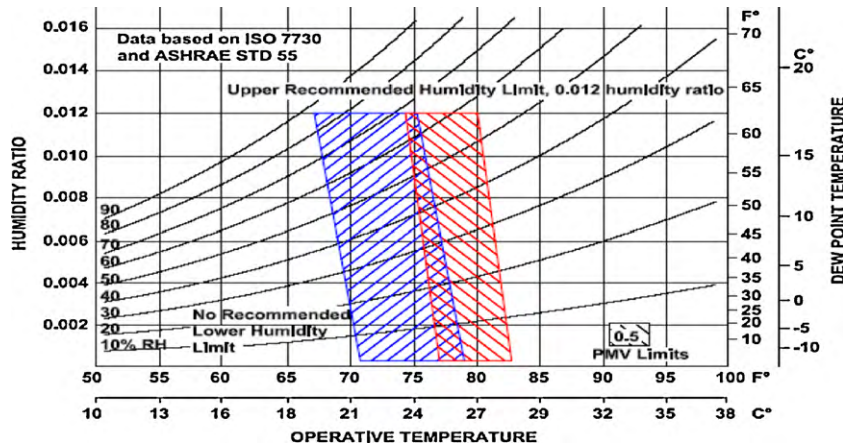

Fig. 3. Comfort zone: ASHRAE STD 55-2004.

Comfort zone, according to ASHRAE Standard 55-2004, shows that humidity ratio has relationship (or correlation) with temperature and relative humidity. Comfort zone at different temperature and relative humidity must have the highest acceptable humidity value, that is 12 g/Kg. ANSI/ASHRAE standard 55-2004, Thermal Environmental Conditions for Human Occupancy, sets an upper limit to absolute humidity levels—0.012 humidity ratio, or  $0.012 \times 7000 = 84$  grains moisture/lb dry air [27].

However, there is no lowest acceptable humidity value. Comfort zone as defined by ASHRAE is the standards used worldwide because in many countries there are no studies and their own comfort zone has not been defined although in reality the climate in each country varies. Comfort zone, therefore, can have different value. Yamtraipat et al. [15,29] conducted a study of thermal comfort standards in air-conditioned buildings in Thailand and found that Thermal comfort standards are that temperature is 26 °C, that relative humidity is 60% and that air velocity is 0.2 m/s.

Thailand is a hot and humid country [30]. According to Fig. 4 [31], the profile of air temperature, relative humidity and humidity ratio (outdoor) in each hour for all year long in 2008 showed that air temperature, relative humidity and humidity ratio were quite out of comfort zone range by ASHRAE Standard 55-2004. In Thailand, there were quite few studies and research on humidity effect on human comfort and health. References were mainly based on foreign studies which depended on ASHRAE Standards only. In fact, each country has different climate, so humidity effect on human also differs. At present, studies on thermal comfort in building are not sufficient since it needs additional studies on humidity effect on human comfort and health in office, residence

and hospital buildings. Therefore, the design and the installation of air conditioning system which complies with the climate in Thailand building, especially hospital buildings, should emphasize relative humidity because it has a great effect on human comfort and health.

Medical studies from foreign countries have shown that it is important to control humidity in hospital buildings and the law is enacted. In Thailand, however, there has no such action and the research on the influence of relative humidity on thermal comfort and good health of human beings is scarce. At present, air-conditioning system used in most houses and offices is split type air conditioner which cannot control temperature and relative humidity at stable level. Inverter air-conditioner can only control temperature at stable level; it cannot control relative humidity at stable level. Therefore, a device to increase or reduce humidity is needed and cost a lot of money. Moreover, it cannot control relative humidity at stable level in the desired range.

The aim of this research was to (1). Assess relative humidity and temperature effects and management on human comfort and health in Thailand hospital building. Because In hospital wards, the air quality has to be better than in other buildings because of the increased risk of infections. (2). The results would be used to design and develop single phase air-conditioning system which could control both temperature and relative humidity (precision inverter air conditioning system) at stable level in a short time with the temperature changes in the range of  $\pm 0.5$  °C and relative humidity changes in the range of 50–60%. There would be intelligent control system for air conditioner using inverter to control the growth, spreading and existence of germs, bacteria, virus, house dust mite and fungi.

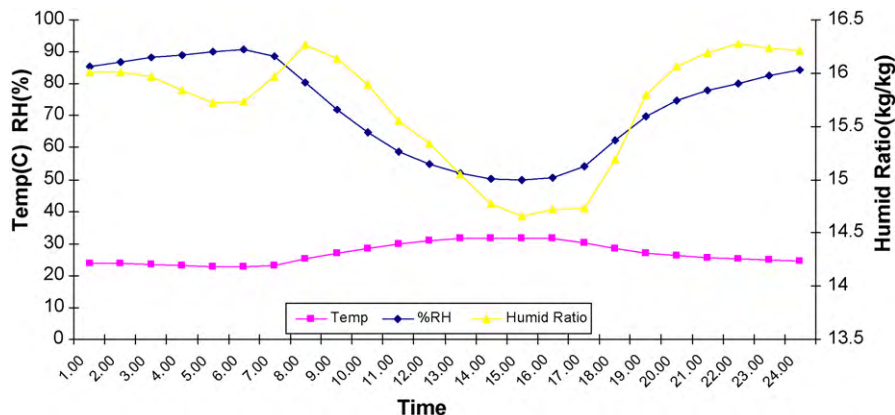

Fig. 4. Profile of air temperature, relative humidity and humidity ratio in Bangkok.



**Table 1**

The details of various air-conditioning systems in the market and the developed air-conditioning system.

Type	Size	Function	Result	Flow rate	Objective	Used
Various air conditioning systems						
Conventional air conditioners	Small	Temperature control only	Wide both temperature and humidity fluctuations	Constant refrigerant flow	Comfort	Human
Inverter air conditioners	Small	Temperature control only	Precise temperature but wide humidity fluctuations.	Variable refrigerant flow	Comfort	Human
Precision air conditioners	Large	Both temperature and humidity control	Precise both temperature and humidity	Constant refrigerant flow	Protection of computer and electronic equipments	Computer and electronic equipments
The developed air-conditioning system						
Precision inverter air conditioners	Small	Both temperature and humidity control	Precise both temperature and humidity	Variable refrigerant flow	Comfort, healthy and protection of computer and electronic equipments	Human and Computer and electronic equipments

This would bring sustainable good health and thermal comfort for the persons in hospital buildings.

### 1.3. The need for the development of this system

It is widely known that there are many HVAC systems which can control room temperature and relative humidity available in the market. Each system is specially designed to meet the demands of the users. The data in Table 1 show the details of various air-conditioning systems in the market. According to the usage objective, there are 2 kinds as follows:

- *Comfort air conditioning system.* Comfort air conditioning systems are designed to control conditions at levels which are suitable for the comfort of people, not the protection of computer-based electrical systems.
- *Precision air conditioning system.* Precision air conditioning systems are primarily designed for cooling electronic equipment, rather than people. It was a protection system for equipment room, data center, network room, computer & telecommunication rooms or remote sites by providing protection from temperature and humidity fluctuations.

Ordinary building air conditioning and heating systems are designed to keep people comfortable. Computers and other sensitive electronics require a system that provides precise humidity control to meet equipment specifications.

Comfort air conditioning system which is widely used in offices or resident areas in Thailand is mostly split type air conditioning system which is small-sized. Split type air conditioners can be classified according to refrigerant flow into 2 types: constant refrigerant flow (CRF), also called conventional air conditioning system and variable refrigerant flow (VRF), also called inverter air conditioning system. Both types of air-conditioners can control only air temperature. It cannot control or retain the level of relative humidity inside the room to the desirable level or the desirable range accurately. The VRF system can retain or control the level of air temperature in the room to the desirable level all the time. The CRF system can control room temperature in wide fluctuation manner. Moreover, the VRF system can save more energy than the CRF system for about 20–25%.

As for the rooms or the offices which require comfort and healthy conditions, the level of temperature and the relative humidity must be controlled accurately. Therefore, besides com-

fort air conditioners, there must be humidifier (to add moisture to the air) and Dehumidifier (to remove moisture from the air) in the room to control the relative humidity to the desirable level. Such devices work independently from the air conditioning system. Therefore, the operation of the air conditioning system and the humidifier/Dehumidifier does not match. Manual setting must be done to control or adjust to the desirable level. To install such devices need a large amount of money.

Precision air conditioning system can control room temperature and relative humidity accurately. This type of air conditioning system contains 2 sets of compressors (each set cannot control the refrigerant flow). Besides, there is humidifier to add the humidity and there is electric heater to add air temperature. If precision air conditioning system is used in rooms or offices, there will be comfort and health. However, it is very difficult in practice because precision air conditioning system is not designed for use in rooms or offices. It is designed to be used in computer & telecommunication rooms where there is 10 times higher heat load than comfort air conditioner. Therefore, it is bigger and more expensive than comfort air conditioner. Therefore, the design of precision air conditioning system for rooms and offices is very important.

According to the above-mentioned reason, there is a strong need to design and develop the air conditioning system for the comfort and healthy conditions for tropical conditions in Thailand. The researchers decided to upgrade conventional air conditioning system to become precision inverter air conditioners which can be used in rooms or offices in a suitable manner. The developed system has the following details as shown in Table 1.

## 2. Delphi technique for researching

The objective of most Delphi applications is the reliable and creative exploration of ideas or the production of suitable information for decision making [33]. The Delphi method is based on a structured process for collecting and distilling knowledge from a group of experts by means of a series of questionnaires interspersed with controlled opinion feedback. The questionnaires are designed to focus on problems, opportunities, solutions, or forecasts. Each subsequent questionnaire is developed based on the results of the previous questionnaire. The process stops when the research question is answered [34].

The Delphi method is a technique for structuring distributed expert group discussion in order to find solutions to complex problems or obtain a consensus of opinion from a group of experts.

It is a good vehicle for collecting opinions from geographically dispersed experts who cannot meet face to face [35,36]. To survey expert opinion, we used the Delphi method which involves a group of experts making private, independent ratings of agreement with a series of statements [37]. The output from the process is statements for which there is substantial consensus in ratings.

The Delphi method has been used in medicine when available data are of a low level of proof, incomplete or contradictory [38], Efstathiou et al. [39] identified healthcare users' key areas of cancer care and services that needed to be developed or improved in Greece and priorities them through a consensus building study. A Delphi technique was used to collect data from a sample of 30 healthcare users in two rounds. Duchet-Niedziolka et al. [40] used Delphi method to obtain professional agreement on vaccination practices in adults with AID or DRID. Morgan and Jorm [41] reported Delphi consensus study on Self-help strategies for sub-threshold depressive symptoms. The aim was to identify strategies that are likely to be both helpful and feasible, and which could be use in a future health promotional campaign. Salliot et al. [42] developed clinical practice guidelines regarding the clinical, laboratory, and imaging data based on data from the literature and experts opinion. Langlands et al. [43] developed recommendations for first aid for depression using the expertise of mental health consumers, carers and clinicians. Winit-Watjana et al. [44] developed explicit criteria for determining high-risk medication use in Thai older patients. It was conducted using a Delphi technique with the three-round survey of 16 geriatric medicine (GM) experts.

### 3. Research methodology

This research was divided into 2 sections: Section 1: assessment of the thermal environment (temperature and relative humidity) effects on human comfort and health using Delphi technique. Section 2: design and develop temperature and relative humidity control system (precision inverter air conditioning system). In this Section, the design and the development of conventional air-conditioner (split type) must be suitable to control temperature and relative humidity in the desired range accurately. Each section has the following details.

#### 3.1. Section 1: assessment of thermal environment (temperature and relative humidity) effects on human comfort and health

##### 3.1.1. Process of Delphi method

This research the Delphi technique used in this study was to brainstorm the ideas from the experts group in 3 following topics:

1. The influence of humidity on the growth of diseases of people living in air conditioned rooms in both direct and indirect ways such as influenza, respiratory diseases, asthma, tuberculosis, eye irritations and allergies.
2. The relationship between relative humidity and the growth as well as the spreading of bacteria, virus, fungi and other pathogens which affect the health of human beings in both direct and indirect ways.
3. Management system of optimal relative humidity and temperature to give human thermal comfort and health in Thailand hospital building.

There were 3 rounds of meeting with individual experts for interview and Q&A section as follows:

Round 1 was Brainstorming to collect opinions of experts in 3 main issues to analyze the data and develop the questionnaire. The tool used in Round 1 was individual interview.

Round 2 was Evaluation of Ideas given by experts for each item in the questionnaire to analyze and evaluate the possibility level of each item and the agreement level of the experts in each item. The statistics used for the analysis consisted of median, mode and quartile. The questionnaire had 5 rating scales.

Round 3 was Re-Evaluation of Ideas. The same questionnaire was used but there were the values for median and interquartile range of experts. If any expert would like to change any answer, they could do so. If there was no correction, it was considered that it was correct.

Rating Scale for 5 levels shows the possibility of each item in the questionnaire as follows:

Scores 5, 4, 3, 2 and 1 mean that the experts think that it is the most likely, highly likely, moderately likely, less likely and least likely, respectively.

##### 3.1.2. Data analysis

The researchers collected the data from the opinions given by the group of 11 medical experts who were medical lectures in medical school. The data were analyzed using SPSS to find out median, mode and Quartile. The difference between median and mode was then analyzed as well as the quartile difference (QD) (the Third Quartile–the First Quartile; Q3–Q1) to judge whether the opinions of the experts in each item was congruent or not and to find out the possibility level of each item. The evaluation criteria was that the interquartile range was not over 1.50 and the difference between median and mode was not over 1. This means that the opinion for such item was congruent. If QD was higher than 1.5 and the difference between median and mode was higher than 1, that means the opinion in such item was not congruent. The possibility level was equivalent to median value.

#### 3.2. Section 2: design and develop temperature and relative humidity control system (precision inverter air-conditioning system)

According to the study in section 1, we realize the effect of temperature and relative humidity on human thermal comfort and health. Therefore, it is necessary to design and develop HVAC system to provide people in air-conditioned room with comfort and health. This research depends on ASHRAE standard because it is applicable to Thailand. So, in this section, a conventional air-conditioning system using inverter was developed to control thermal environment (temperature and relative humidity) inside the room to reach the appropriate temperature and relative humidity with precision.

##### 3.2.1. Dehumidification

Dehumidification in this study depended on mechanical dehumidification process or cooling process. This is based on the principle that the condensation of water at cooling coil reduces the temperature inside the room, resulting in lower humidity.

Usually the air inside the room at a certain temperature will have one dew point temperature. If the air passes through cooling coil of evaporator whose surface temperature is lower than dew point temperature which the air passes, there will be condensation of water, resulting in lower amount of water in the air. The amount of condensation of water depends on the difference value between dew point temperature and surface temperature. Therefore, we can control the temperature at cooling coil by controlling the flow rate of refrigerant and the spreading rate of air passing the cooling coil.

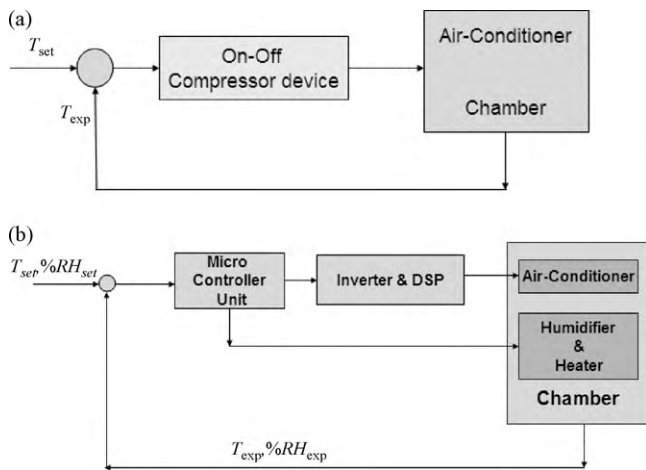

**Fig. 5.** Block diagram of air conditioning system. (a) conventional air conditioning system and (b) precision inverter air conditioning system.

### 3.2.2. Details of system

The main components of temperature and humidity control system by precision inverter air-conditioning system (split type) with inverter installed to control the speed of compressor motor (single phase), ultrasonic humidifier to increase water volume in the air, electric heater to increase temperature inside the room and control unit to control operation of each element in automation (as shown in Fig. 5(b)). The process of the system in Fig. 5(b) is precision inverter air-conditioning system which differs from conventional air conditioning system in which compressor works in on-off without humidity control (as shown in Fig. 5(a)).

### 3.2.3. Operating of system

The Operating of system as follows: Micro Controller Unit (MCU) detects the air temperature and relative humidity in the chamber ( $T_{exp}, \%RH_{exp}$ ) and compare them with the default or set value ( $T_{set}, \%RH_{set}$ ). If the air temperature is higher than the set value, MCU will send the data to DSP (Digital Signal Processing) to increase the speed of compressor motor to increase the flow rate of refrigerant. When the air temperature becomes as set, the speed of the compressor motor will be decreased as appropriate which is decided by fuzzy logic program. In case that relative humidity is lower than the set value, MCU will tell ultrasonic humidifier to increase the amount of vapor in the chamber. If the relative humidity is higher than the set value, the humidity in the chamber must be decreased. In this case where the humidity is reduced, the air temperature in the chamber will become lower as well. MCU will tell electric heater to increase the air temperature in the chamber. Therefore, such system can control the air temperature and relative humidity in the desired range as always.

## 4. Experimental

Due to the fact that this research was intended to create precision inverter air-conditioning system which could control temperature and humidity with accuracy, the experiment was to be done in testing room where the environmental condition in terms of internal heat and external heat reflected the reality, without modification or heat control in order to show that precision inverter air conditioning system could control temperature and humidity inside the room in the desired range accurately no matter what the internal heat or external heat was.

According to Yamtraipat et al. [15], comfort temperature in air conditioned buildings in Thailand is temperature at 26 °C and 60%RH. ASHRAE 55-2004 shows that a summer maximum comfort

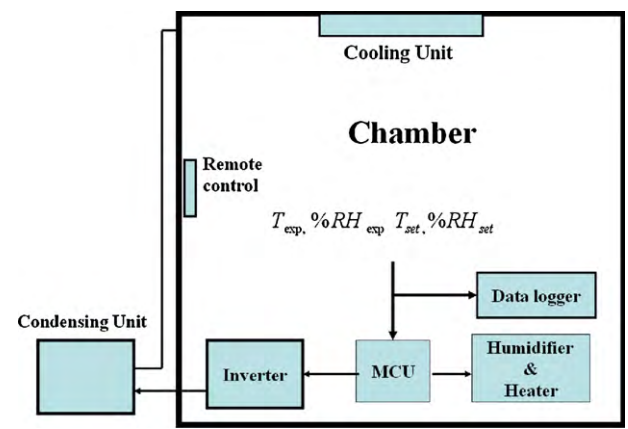

**Fig. 6.** Schematic diagram of the experimental setup.

temperature for acceptable is 27.5 °C [32]. And the ASHRAE 55-2004 indicate that higher bedroom temperatures can be accepted if a fan is used: ASHRAE indicates an acceptable increase of up to 3 °C [32]. Therefore, climate temperature and relative humidity in testing room in 2 cases were set at 27.5 °C and 50–60%RH, respectively.

There were 2 cases according to the testing rooms. Case 1 was done in a classroom as a testing room. Case 2 was done in a bedroom as a testing room. Both rooms had the same dimension, or 20 m<sup>2</sup>. The same testing device was installed in both rooms. The time for the experiment in both cases was considered in terms of the difference between temperature and relative humidity outside the rooms which change. In Case 1 (Classroom), the test was done from 5.00 to 9.00 because outdoor temperature increased but indoor relative humidity decreased as shown in Fig. 9(b). In Case 2 (Bedroom), the test was done from 23.00 to 6.00 because outdoor temperature decreased but indoor relative humidity increased as shown in Fig. 10(b).

The tools used to sensor and measure climate temperature, refrigerant temperature, relative humidity and pressure were as follows. Refrigerant temperatures were measured using RTDs (Pt100 X) with an accuracy of 0.05 ± °C. Humidity Relative and air temperatures were measured using STH15 with an accuracy of ±0.1%RH and 0.05 ± °C, respectively. The face air velocity was measured with a hot wire anemometer with an accuracy of ±1%. pressure gauges with an accuracy of ±0.2% of full scale.

Fig. 6 shows the main devices installed in the testing rooms for both cases: single phase split type air conditioner (18000 BTU), ultrasonic humidifier (200 ml/h), electric heater (2 kW) and inverter to control the speed of compressor (single phase type). The indoor air temperature and relative humidity are detected by STH15. The data were recorded by Hioki datalogger.

## 5. Results and discussion

The results from assessment of the thermal environment (temperature and relative humidity) effects on human comfort and health in Thailand hospital building using delphi technique and design and develop temperature and relative humidity control system can be shown as follows.

### 5.1. Results from Section 1: Assessment of the thermal environment (temperature and relative humidity) effects on human comfort and health

Results from the interview with each expert were analyzed to create a questionnaire of 40 items. Then, each expert gave their opinion towards each item. The feedback for the questionnaire was analyzed to find out the congruence and the possibility level for

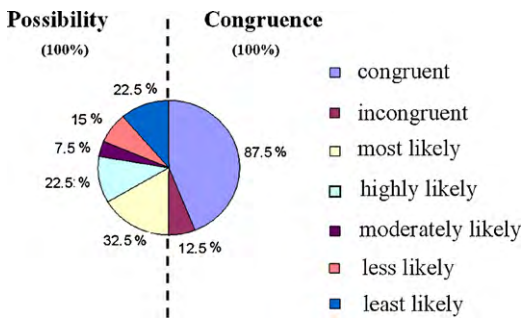

Fig. 7. The overall result from the data analysis.

each item. The result from the statistical data analysis can be seen in Fig. 7.

Graph in Fig. 7 can be divided into 2 sides. Right side shows the congruence of items as given by experts. Congruence and incongruence were 87.5% and 12.5%, respectively. Left side shows the possibility level of items as in the highest, higher, moderate, less likely and the least likely and the values were 32.5%, 22.5%, 7.5%, 15% and 22.5%, respectively.

In Fig. 8(a), there were 5 items (red spots) whose QD value was 2. This means that experts showed incongruence towards such items. The mean of 5 items was between 2 and 5. For items with low or high mean and its QD was higher than 1.5 means, it means that the opinion of experts was highly different. If mean was low or high and QD was below 1.5, it means that the opinion of experts was only slightly different.

Median value shows that each item was likely for several levels: from the highest, high, moderate, less, and the least. The relationship between mean and median was not linear for 100%. Items whose mean was equal but whose median was different means that the majority of the experts were equal to median. For example (in Fig. 8(b)), there were 3 questions whose median value was 3. Out of 3 items, the lowest score was 2.63 and the highest score was 3.63.

This means that although the average was different but the weight for score given by the experts was at moderate level (median = 3).

All 40 items were analyzed using mean, median, Quartile Difference, congruence and possibility level. The results from the statistical data analysis, there were 22 items which experts considered as more likely to the most likely. There were 9 items which experts considered as the least likely. This results were useful to set the direction for indoor thermal environment management in Thailand's buildings. Therefore, the development of HVAC in this research was based on the agreement or congruence of experts to comply with Thai climate and requirements.

As for the study of relative humidity which affect the health of people living in the hospital buildings in Thailand, the questions which the experts agreed with and showed the probability at the

more likely and the most likely level were as follows:

- Thailand is tropical; therefore, there is diversity in tropical medicine and diseases.
- Humidity has an indirect effect on human health.
- Temperature and humidity are factors which cause diseases and affect the symptoms of patients.
- Temperature and Relative Humidity has an indirect influence on diseases, rhinitis and allergies, asthma, tuberculosis, influenza, and sinusitis.
- Humidity in the air influences the growth and spreading of bacteria, virus, house dust mite and fungi.
- Relative humidity is controlled in LASIK rooms in hospitals.
- The value of relative humidity and temperature in the range of comfort zone by ASHRAE can be applied in Thailand.
- The influence of relative humidity on bacteria, virus, fungi and house dust mite, according to ASHRAE, can be applied in Thailand.
- Suitable relative humidity in air conditioned rooms in Thailand should be around 50–60%.
- Temperature in air conditioned rooms for comfort should be from 25–26 °C.
- The control in relative humidity in the range of comfort zone will give good results to the health and the comfort of people living in air conditioned rooms.
- Rooms whose relative humidity and temperature are controlled are to keep the sustainability of the medical devices and equipment only.
- Air-conditioned rooms which can precisely control the temperature and relative humidity will give better results to the health and comfort than traditional air conditioned rooms.

Here are items which the experts considered as the least likely.

- Relative humidity is controlled in operation rooms, burn unit rooms, aseptic rooms, doctor rooms in hospitals.
- There is research on the effects of relative humidity on diseases in people inside air conditioned rooms in Thailand.
- There is research on the effects of humidity on comfort for people in air conditioned rooms in Thailand.
- There is public health law on setting relative humidity and suitable temperature in controlled buildings or public buildings.
- There is research on air purifier to reduce allergy caused by house dust mite.

5.2. Results from Section 2: Design and develop temperature and relative humidity control system (precision inverter air-conditioning system)

According to results in section 1, we know the effects of temperature and humidity on diseases in people inside air conditioned rooms in both direct and indirect ways in Thailand, effects of

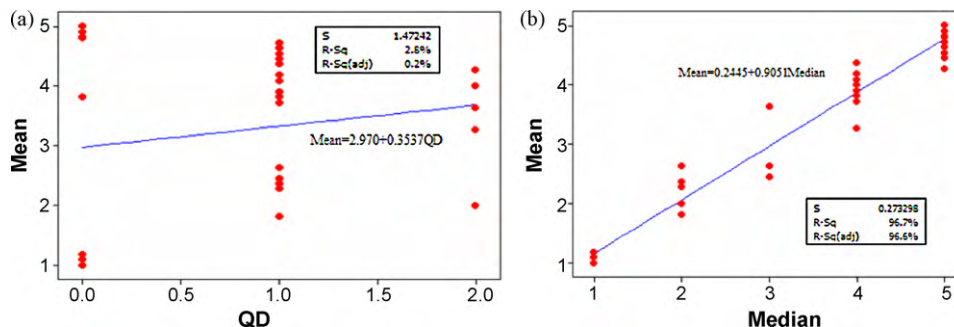

Fig. 8. Relationship between (a) Mean and QD and (b) Mean and Median.



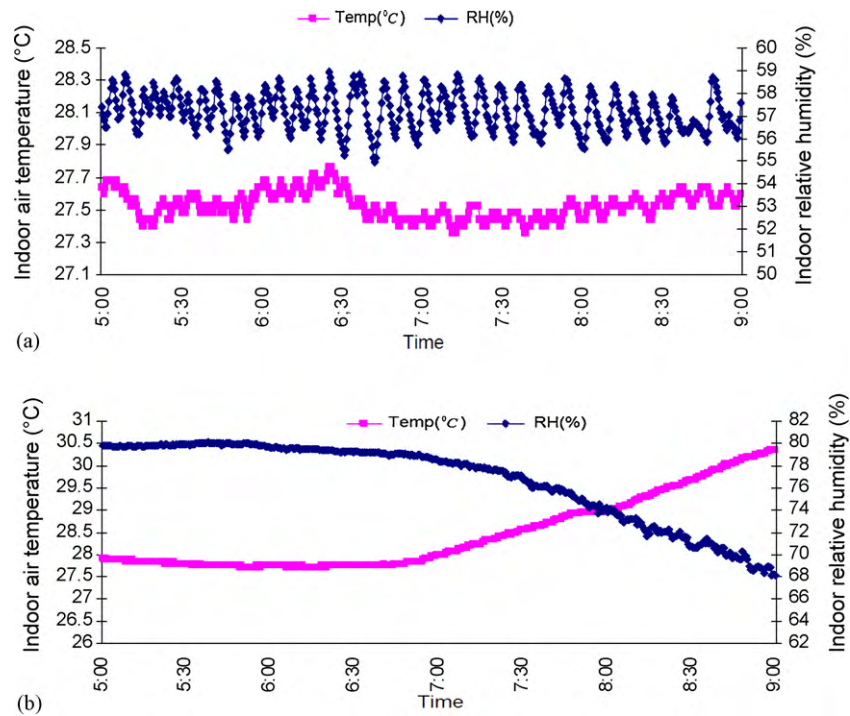

Fig. 9. Profile of air temperature and relative humidity: Case 1 (classroom). (a) indoor and (b) outdoor.

humidity on the growth and spreading of diseases, and operation system to control temperature and humidity in hospital buildings. Therefore, if we can control indoor thermal environment in the desired range, there will be benefits for thermal comfort and health.

Results from operation with precision inverter air conditioning system to control temperature and relative humidity in the testing

rooms in 2 cases were shown in Figs. 9 and 10. As for Fig. 11, they are Profile of indoor humidity ratio in 2 cases.

Fig. 9(a) shows Profile of indoor air temperature and relative humidity in Case 1 (classroom). Indoor air temperature and relative humidity were set at 27.5 °C and 50–60%, respectively. Results of air temperature and relative humidity recorded by data logger every

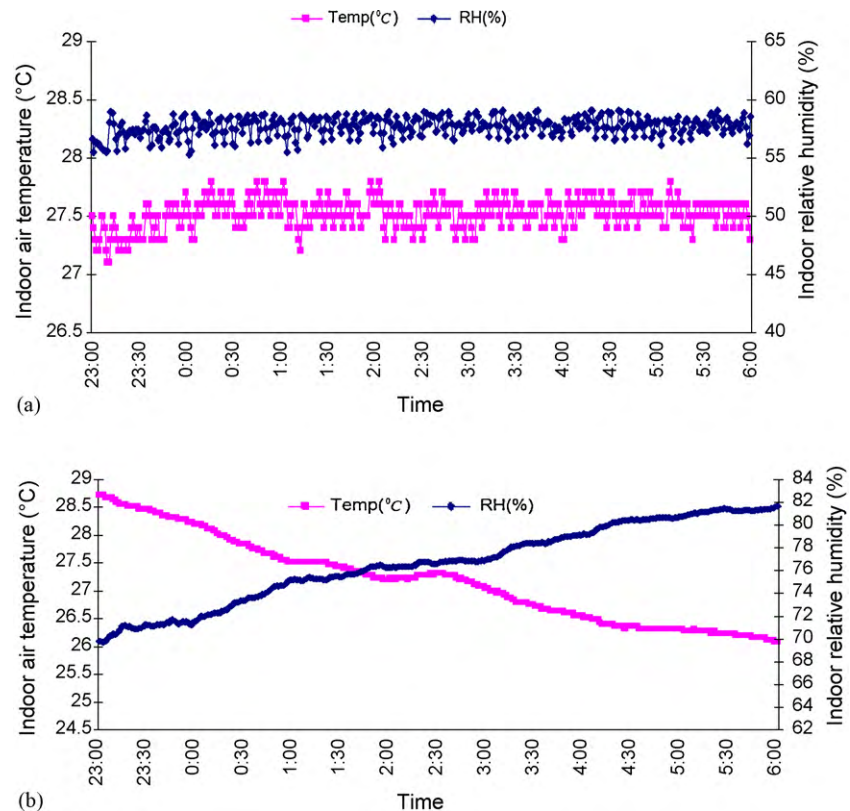

Fig. 10. Profile of air temperature and relative humidity: Case 2 (bedroom). (a) indoor and (b) outdoor.



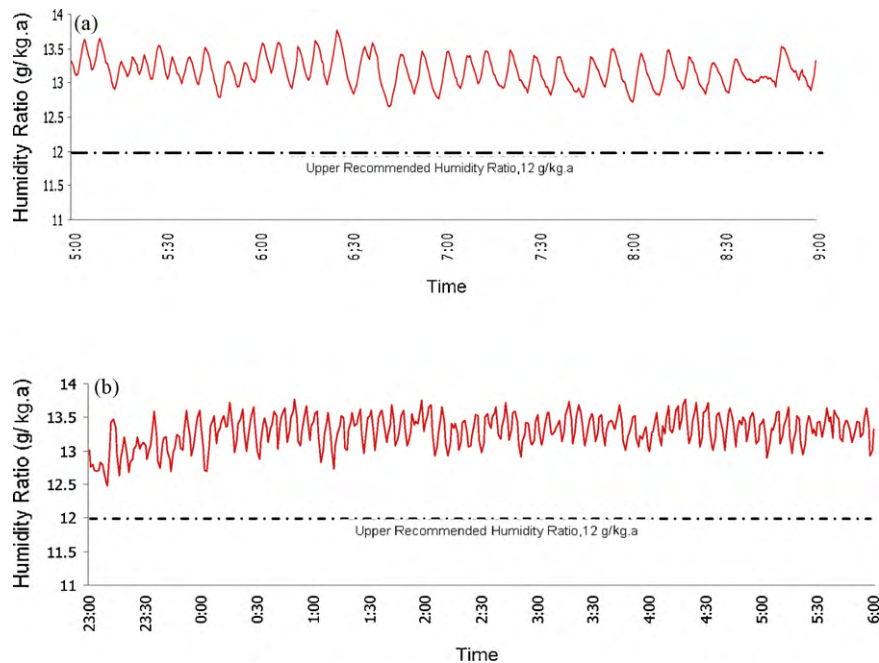

Fig. 11. Profile of indoor humidity ratio: (a) Case 1 (classroom) and (b) Case 2 (bedroom).

30 s show that the minimum value, maximum value and average value of air temperature are 27.36 °C, 27.76 °C and 27.52 °C, respectively. The minimum value, maximum value and average value of relative humidity are 54.98%, 58.91% and 57.18%, respectively. It can be seen that indoor air temperature changed by  $\pm 0.2$  °C when compared to the setting. The average air temperature was 0.02 °C higher than the setting. Relative humidity changed in the desired range, that is 50–60%.

Fig. 9(b) shows Profile of outdoor air temperature and relative humidity in Case 1 (classroom). The minimum value, maximum value and average value of air temperature are 27.72 °C, 30.36 °C and 28.45 °C, respectively. The minimum value, maximum value and average value of relative humidity are 68.13%, 80.09% and 76.69%, respectively. According to Fig. 9(b), the more the time passes, the higher the air temperature but the relative humidity will decrease.

Fig. 10(a) shows Profile of indoor air temperature and relative humidity in Case 2 (bedroom). Indoor air temperature and relative humidity were set at 27.5 °C and 50–60%, respectively. Results of air temperature and relative humidity recorded by data logger every 30 s show that the minimum value, maximum value and average value of air temperature are 27.1 °C, 27.8 °C and 27.52 °C, respectively. The minimum value, maximum value and average value of relative humidity are 55.3%, 59.1% and 57.74%, respectively. It can be seen that the indoor air temperature changed by  $\pm 0.35$  °C when compared to the setting. The average air temperature was 0.02 °C higher than the setting. Relative humidity changed in the desired range, that is 50–60%.

Fig. 10(b) shows Profile of outdoor air temperature and relative humidity in Case 2 (bedroom). The minimum value, maximum value and average value of air temperature are 26.08 °C, 28.72 °C and 27.18 °C, respectively. The minimum value, maximum value and average value of relative humidity are 69.71%, 81.69% and 76.66%, respectively. According to Fig. 10(b), the more the time passes, the lower the air temperature but the relative humidity will increase.

Fig. 11(a) shows Profile of indoor humidity ratio in Case 1 (classroom). The minimum value, maximum value and average value of humidity ratio are 12.64 g/kg.a, 13.76 g/kg.a and 13.17 g/kg.a,

respectively. The value of indoor humidity ratio from the experiment is higher than the highest acceptable ASHRAE value for around 1.17 g/kg.a on average.

Fig. 11(b) shows Profile of indoor humidity ratio in Case 2 (bedroom). The minimum value, maximum value and average value of humidity ratio are 12.47 g/kg.a, 13.77 g/kg.a and 13.30 g/kg.a, respectively. The value of indoor humidity ratio from the experiment is higher than the highest acceptable ASHRAE value for around 1.30 g/kg.a in average.

## 6. Conclusions

Thailand is tropical. Human thermal comfort and health of Thai people, therefore, depend on 2 main factors which are difficult to control. They are air temperature and too high relative humidity. It is widely known that relative humidity affects the growth and spreading of bacteria, virus, house dust mite and fungi, especially in air-conditioned rooms with closed covers or without good ventilation system. This affects the comfort and health of people living inside. There are only few results from medical research and the studies on the development of HVAC system to offer comfort and health in Thailand. Therefore, ASHRAE standards must be used as the main basis.

This research was done to study the effects of temperature and relative humidity on human comfort and health of people in Thailand for the development of novel air conditioning system in tropical regions. Then, HVAC system was designed and developed to create good indoor thermal environment in air-conditioned rooms in Thailand buildings. The congruence of the experts is used to comply with the climate and requirements of Thai people.

Delphi technique results in section 1 showed that the experts agreed on the fact that relative humidity and air temperature affects thermal comfort and health of human beings. Therefore, in air-conditioned rooms, there should be air temperature and relative humidity control system to achieve thermal comfort and good health for the persons inside the room, especially in hospital buildings because it is good for patients and staff members. Due to the fact that there are only few studies on thermal environment which

is suitable for Thailand air conditioned rooms, ASHRAE standards is used instead.

Air temperature and relative humidity control system (precision air conditioning system) using inverter air conditioning system (single phase) in this research could control air temperature and relative humidity in the room as a desired condition in 2 cases (Classroom and Bedroom). The changes were different from the set value around  $\pm 0.2^\circ\text{C}$  (Case 1: Classroom) and  $\pm 0.35^\circ\text{C}$  (Case 2: Bedroom) and it could control relative humidity between 50–60% (in 2 cases) which was the appropriate range form Thai climate. If the system is used in the buildings which need to control thermal environment such as hospitals, patient's rooms, school, houses or offices, there will be thermal comfort and good health for the people living inside.

According to the results from two experimental cases, it was found that the average energy consumption of precision inverter air conditioning system was about 1.4 Kwh. Generally, there was a comparison between energy need of precision inverter air conditioning system and conventional and inverter air conditioning system. It was found that energy consumption of conventional and inverter air conditioning system was 1.5 Kwh and 1.2 Kwh, respectively. When the inverter air conditioning system was developed into precision inverter air conditioning system, an electric heater with 2 Kw had to be included. For this reason, energy consumption of precision inverter air conditioning system increased by 16% because electric heater had to work heavy load during dehumidification process. In overall, energy consumption of precision inverter air conditioning system was still less than conventional air conditioning system for about 7.5%.

Therefore, buildings such as residential places, schools, hospitals or offices with installed conventional air conditioning system could change into precision inverter air conditioning system. It would be good for human comfort and health. Moreover, it saves electricity consumption by 7.5%. The result from the electricity saving plan for 7.5% of energy consumption of split type air conditioning system in residential and commercial sector was around 2038 Gwh/year and accounted for 1.5% of the total electric consumption for the whole country.

## Acknowledgements

The researchers would like to say thank you to the medical specialists from the Faculty of Medicine Ramathibodi Hospital: Mahidol University, the Faculty of Medicine Siriraj Hospital: Mahidol University and the Faculty of Tropical Medicine: Mahidol University for their kindness during the interview and for filling out the questionnaire. This study was supported financially by the Energy Policy and Planning Office (EPPO), Ministry of Energy, Thailand. We also say thank you to Mr. Suthee Ploisawaschai for his proofreading of this article.

## References

- [1] J. Skoog, N. Fransson, L. Jagemar, Thermal environment in Swedish hospitals: summer and winter measurements, *Energy and Buildings* 37 (2005) 872–877.
- [2] L.Z. Zhang, J.L. Niu, Indoor humidity behaviors associated with decoupled cooling in hot and humid climates, *Building and Environment* 38 (2003) 99–107.
- [3] D. Holm, F.A. Engelbrecht, Practical choice of thermal comfort scale and range in naturally ventilated buildings in South Africa, *Journal of the South African Institution of Civil Engineering* 47 (2005) 9–14.
- [4] J. Pfaffertott, S. Herkel, J. Wapler, Thermal building behaviour in summer: long-term data evaluation using simplified models, *Energy and Buildings* 37 (2005) 844–852.
- [5] ANSI/ASHRAE Standard 62-2001: Ventilation for Acceptable Indoor Air Quality, American Society of Heating, Refrigerating and Air-Conditioning Engineers Inc., Atlanta, GA, (2001).
- [6] M. Sato, S. Fukayo, E. Yano, Adverse environmental health effect of ultra-low relative humidity indoor air, *Journal of Occupational Health* 45 (2003) 133–136.
- [7] A.V. Baughman, E.A. Arens, Indoor humidity and human health—part I: literature review of health effects of humidity-influenced indoor pollutants, *ASHRAE Transactions* 102 (1996) 193–211.
- [8] E.A. Arens, A.V. Baughman, Indoor humidity and human health: part II—buildings and their systems, *ASHRAE Transactions* 102 (1996) 212–221.
- [9] R.L. Hwang, T.P. Lin, M.J. Cheng, J.H. Chien, Patient thermal comfort requirement for hospital environments in Taiwan, *Building and Environment* 42 (2007) 2980–2987.
- [10] B.W. Olesen, The philosophy behind EN15251: indoor environmental criteria for design and calculation of energy performance of buildings, *Energy and Buildings* 39 (2007) 740–749.
- [11] A.V. Arundel, E.M. Sterling, J.H. Biggin, T.D. Sterling, Indirect health effects of relative humidity indoor environments, *Environmental Health Perspectives* 65 (1986) 351–361.
- [12] L. Harriman, G. Brundrett, R. Kittler, Humidity control design guide for commercial and institutional buildings, *ASHRAE* (2001) 205.
- [13] C.A. Balaras, E. Dascalaki, A. Gaglia, HVAC and indoor thermal conditions in hospital operation rooms, *Energy and Buildings* 39 (2007) 454–470.
- [14] P. Wolkoff, S.K. Kjaergaard, The dichotomy of relative humidity on indoor air quality, *Environment International* 33 (2007) 850–857.
- [15] N. Yamtraipat, J. Khedari, J. Hirunlabh, Thermal comfort standards for air conditioned buildings in hot and humid Thailand considering additional factors of acclimatization and education level, *Solar Energy* 78 (2005) 504–517.
- [16] F.H. Mallick, Thermal comfort and building design in the tropical climates, *Energy and Buildings* 23 (1996) 161–167.
- [17] W. Lester, The influence of relative humidity on the infectivity of air-borne influenza A virus (PR8 Strain), *The Journal of Experimental Medicine* 88 (1948) 361–368.
- [18] N. Hashiguchi, M. Hirakawa, Y. Tochihiro, Y. Kaji, C. Karaki, Effects of setting up of humidifiers on thermal conditions and subjective responses of patients and staff in a hospital during winter, *Applied Ergonomics* 39 (2008) 158–165.
- [19] I. Atmaca, A. Yigit, Predicting the effect of relative humidity on skin temperature and skin wettedness, *Journal of Thermal Biology* 31 (2006) 442–452.
- [20] K. Srinavin, S. Mohamed, Thermal environment and construction workers' productivity: some evidence from Thailand, *Building and Environment* 38 (2003) 339–345.
- [21] H. Tsutsumi, S. Tanabe, J. Harigaya, Y. Iguchi, G. Nakamura, Effect of humidity on human comfort and productivity after step changes from warm and humid environment, *Building and Environment* 42 (2006) 4034–4042.
- [22] A.C. Lowen, S. Mubareka, J. Steel, P. Palese, Influenza virus transmission is dependent on relative humidity and temperature, *PLoS Pathogen* 3 (10) (2007) 1470–1476.
- [23] J.H. Hemmers, K.C. Winkler, S.M. Kool, Virus survival as a seasonal factor in influenza and poliomyelitis, *Nature* 188 (4748) (1960) 430–431.
- [24] Y. Hiraga, R. Mikami, M. Kaji, I. Mizoguchi, S. Kudo, T. Satake, Clinical epidemiological study on the use of ultrasonic humidifier in low-humidity rooms of apartment buildings heated by a central heating system, *Jpn. J. Thorac. Dis.* 19 (9) (1981) 631–640.
- [25] H. Tsutsumi, et al., Effects of low humidity on sensation of eye dryness caused by using different type of contact lenses in summer season, *Proceedings of Indoor Air* (2002) 394–399.
- [26] T. Ibamoto, et al., Study on higher temperature and low humidity air conditioning (Part1-Part4), Annual Meeting of SHASE, (2000)(2001):Part1-2: 821–828:Part3-4: 1325–1332.
- [27] ANSI/ASHRAE 55-2004, Thermal environmental conditions for human occupancy, American Society of Heating Refrigerating and Air-conditioning Engineers Inc., Atlanta, USA, 2004.
- [28] ASHRAE Handbook: Fundamentals, American Society of Heating Refrigerating and Air-Conditioning Engineers Inc., Atlanta, GA, 2001.
- [29] N. Yamtraipat, J. Khedari, J. Hirunlabh, J. Kunchornrat, Assessment of Thailand indoor set-point impact on energy consumption and environment, *Energy Policy* 34 (2006) 765–770.
- [30] J. Khedari, N. Yamtraipat, N. Pratitong, J. Hirunlabh, Thailand ventilation comfort chart, *Energy and Buildings* 32 (2000) 245–249.
- [31] T. Sookchaiya, N. Yantraipat, V. Monyakul, S. Thepa, Experimental studies of a Humidity Ratio Profile using inverter and conventional air-conditioning system, in: Proceedings of the World Renewable Energy Congress 2009-ASIA, The 3rd International Conference on "Sustainable Energy and Environment (SEE 2009)", Bangkok, Thailand, (2009) 840–845.
- [32] P. Fanger, Thermal Comfort: Analysis and Applications in Environmental Engineering, McGraw-Hill Book Company, United States, 1970.
- [33] M. Adler, E. Ziglio, Gazing into the oracle: The Delphi Method and its application to social policy and public health, Jessica Kingsley Publishers, London, 1996.
- [34] G.J. Skulmoski, F.T. Hartman, J. Krahn, The Delphi Method for Graduate Research, *Journal of Information Technology Education* 6 (2007).
- [35] C. Powell, The Delphi technique: Myths and realities, *Journal of Advanced Nursing* 41 (2003) 376–382.
- [36] H.A. Linstone, M. Turoff, The Delphi method: Techniques and applications, Addison Wesley Publishing, Reading, MA, 1975.
- [37] J. Jones, D. Hunter, Qualitative research: consensus methods for medical and health services research, *BMJ* 311 (1995) 376–380.
- [38] F. Hasson, S. Keeney, H. McKenna, Research guidelines for the Delphi survey technique, *Journal of Advanced Nursing* 32 (2000) 1008–1015.
- [39] N. Efstathiou, J. Ameen, A. Coll, A Delphi study to identify healthcare users' priorities for cancer care in Greece, *European Journal of Oncology Nursing* 12 (2008) 362–371.

- [40] P. Duchet-Niedziolka, et al., Vaccination in adults with auto-immune disease and/or drug related immune deficiency: Results of the GEVACCIM Delphi survey, *Vaccine* 27 (2009) 1523–1529.
- [41] A.J. Morgan, A.F. Jorm, Self-help strategies that are helpful for sub-threshold depression: A Delphi consensus study, *Journal of Affective Disorders* 115 (2009) 196–200.
- [42] C. Salliot, et al., Diagnosis of peripheral psoriatic arthritis: Recommendations for clinical practice based on data from the literature and experts opinion, *Joint Bone Spine* 76 (2009) 532–539.
- [43] R.L. Langlands, A.F. Jorm, C.M. Kelly, B.A. Kitchener, First aid for depression: A Delphi consensus study with consumers carers and clinicians, *Journal of Affective Disorders* 105 (2008) 157–165.
- [44] W. Winit-Watjana, P. Sakulrat, J. Kespichayawattana, Criteria for high-risk medication use in Thai older patients, *Archives of Gerontology and Geriatrics* 47 (2008) 35–51.